

Weller®

WSP 80

- D** Betriebsanleitung
- F** Manuel d'Utilisation
- I** Istruzioni per l'uso
- GB** Operating Instruction
- TR** Kullanım açıklamaları

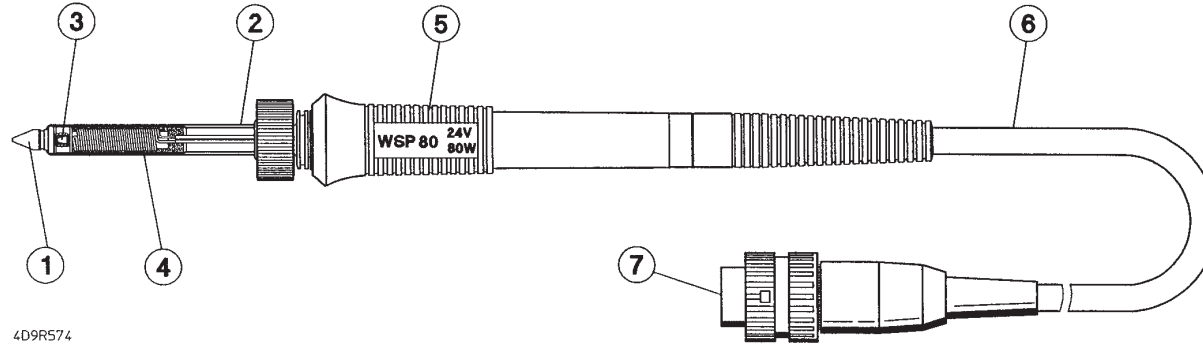

4D9R574

D

1. Lötspitze
2. Spitzenhülse zur Befestigung der Lötspitze
3. Temperatursensor
4. Heizwicklung
5. Ergonomischer Griff aus antistatischem Kunststoff
6. Temperaturbeständige antistatische Silikonleitung
7. Verriegelbarer Anschlußstecker

F

1. Panne
2. Douille de fixation de la panne
3. Sonde de température
4. Enroulement chauffant
5. Manche ergonomique en plastique antistatique
6. Câble silicone antistatique à l'épreuve de la chaleur
7. Connecteur d'alimentation verrouillable

I

1. Punta di brasatura
2. Bussola di punta per il fissaggio della punta
3. Sensore di temperatura
4. Avvolgimento termico
5. Impugnatura ergonomica in plastica antistatica
6. Conduttore in silicone antistatico resistente alla temperatura
7. Connettore con dispositivo di chiusura

GB

1. Soldering bit
2. Bit-sleeve for bit fastening
3. Temperature sensor
4. Heater element
5. Ergonomic handle made from antistatic plastic
6. Heat resistant antistatic silicone cable
7. Lockable connector

TR

1. Lehim kalemi uçları
2. Lehim kalemi ucu için uç yuvası
3. Isı sensörü
4. Isıtma sargısı
5. Antistatik plastikten mamul ergonomik kulp
6. Isıya dayanıklı antistatik silikon iletken hat
7. Kilitlenebilir bağlantı fişi

1. Beschreibung

Der Weller Micro-Lötkolben WSP 80 zeichnet sich durch das präzise und blitzschnelle Erreichen der Löttemperatur aus. Durch ein besonders leistungsfähiges 80 W Heizelement wird ein ausgezeichnetes, dynamisches Verhalten erreicht. Zusammen mit der schlanken Bauform und dem einfachen Spitzenwechsel findet dieser Lötkolben universellen Einsatz von extrem feinen Lötarbeiten bis hin zu solchen mit erhöhtem Wärmebedarf.

Mit einer integrierten Potentialausgleichsleitung besteht die Möglichkeit einen gewünschten Potentialausgleich zur Lötspitze herzustellen. Durch die antistatische Ausführung Ausführung von Griff und Zuleitung erfüllt der Lötkolben alle Anforderungen der EGB-Sicherheit.

Technische Daten

Anschlußspannung:	24 V
Leistung:	80 W
Aufheizzeit:	ca. 10 sec. (50°C-350°C)
Max. Temp.:	450°C
Anschließbar an:	alle 80 W Versorgungseinheiten

2. Inbetriebnahme

Lötkolben in der Sicherheitsablage ablegen. Alle brennbaren Gegenstände aus der Nähe des Lötwerkzeugs bringen. Den Anschlußstecker (7) in die Versorgungseinheit einstecken und verriegeln. An der Versorgungseinheit die gewünschte Temperatur einstellen. Nach Ablauf der benötigten Aufheizzeit die Lötspitze mit etwas Lot benetzen.

3. Potentialausgleich

Ein gewünschter Potentialausgleich zur Lötspitze kann über das verwendete Versorgungsgerät hergestellt werden. Die Anschlußmöglichkeiten einer Potentialausgleichsleitung sind in der Betriebsanleitung der Versorgungseinheit beschrieben.

D

4. Arbeitshinweise

Spitzenwechsel

- Lötkolben waagrecht halten.
- Rändelmutter der Spitzenhülse (2) lösen.
- Spitzenhülse (2) nach vorne abziehen.
- Lötspitze befindet sich nun lose in der Spitzenhülse.

Vorsicht: Lötspitze heiß!!

Die heiße Lötspitze / Messspitze nicht auf dem Reinigungsschwamm oder Kunststoffoberflächen ablegen bzw. abkühlen.

Bei der Verwendung von mehreren Lötspizentypen, wird empfohlen Lötspitze (1) und Spitzenhülse (2) zusammen als schnelles Wechselsystem zu benutzen.

Die Wärmeübertragungsflächen von Heizkörper und Lötspitze sauber halten.

Antistatische Kunststoffe sind zur Verhinderung von statischen Ladungen mit leitenden Füllstoffen versehen. Dadurch sind auch die Isoliereigenschaften des Kunststoffes vermindert. Es dürfen keine Arbeiten an unter Spannung stehenden Teilen durchgeführt werden.

Die Betriebsanleitung der verwendeten Versorgungseinheit ist zu dieser Betriebsanleitung ergänzend gültig.

5. Zubehör

Lötspitzen Bilder LT-Tips siehe Seite 7 - 9

Technische Änderungen vorbehalten!

1. Description

Le micro fer à souder Weller WSP 80 se distingue par la précision et la rapidité avec lesquelles il atteint la température de soudage. Un élément chauffant de 80 W, particulièrement performant, lui confère d'excellentes caractéristiques dynamiques. Par sa forme élançée et par le changement aisé de la panne, ce fer à souder est d'un emploi universel et permet de réaliser aussi bien des soudures d'une extrême précision que des travaux nécessitant une chaleur importante.

Une ligne d'équipotentialité intégrée permet, si l'utilisateur le souhaite, d'effectuer une compensation du potentiel avec la panne. Grâce à son manche et à son câble antistatiques, le fer à souder remplit tous les critères de sécurité requis pour les composants craignant les décharges électrostatiques.

Caractéristiques techniques

Tension d'alimentation:	24 V
Puissance:	80 W
Durée de chauffe:	ca. 10 sec. (50°C-350°C)
Température maxi.:	450°C
Compatible avec:	toutes les stations 80 W

2. Mise en service

Placer le fer à souder dans le support de sécurité. Eloigner tous les objets inflammables du fer à souder. Brancher le connecteur d'alimentation (7) sur l'unité d'alimentation et le verrouiller. Régler la température souhaitée sur l'unité d'alimentation. Une fois la durée de mise en température écoulée, étamer la panne avec un peu de soudure.

3. Compensation du potentiel

Si une compensation du potentiel avec la panne est souhaitée, elle peut être réalisée au travers de l'unité d'alimentation. Les possibilités de raccordement d'une ligne d'équipotentialité sont décrites dans la notice de l'unité d'alimentation.

F

4. Instructions d'emploi

Changement de panne

- Tenir le fer à souder horizontalement.
- Desserrer l'écrou moleté de la douille de la panne (2).
- Retirer la douille de la panne (2) vers l'avant.
- La panne n'est maintenant plus fixée dans la douille.

Attention: La panne est brûlante!

Ne pas stocker ou déposer la panne chaude / la panne de mesure sur l'éponge de nettoyage ou sur des surfaces plastiques.

Si plusieurs types de pannes sont utilisés, il est recommandé d'employer la panne (1) et la douille (2) sous forme d'ensemble complet pour un changement rapide.

Garder propre les surfaces de contact entre la panne et l'élément chauffant pour maintenir le transfert de chaleur optimum.

Afin d'éviter les charges statiques, les plastiques antistatiques contiennent des substances conductrices, ce qui entraîne également une baisse des propriétés isolantes du plastique. Ne pas travailler sur des éléments sous tension.

En plus du présent mode d'emploi, observer le mode d'emploi de l'unité d'alimentation utilisée.

5. Accessoires

Pannes figure Pannes LT, voir les pages 7 - 9.

Sous réserve de modifications techniques!

1. Descrizione

Il microbrasatore Weller WSP 80 è caratterizzato dal raggiungimento veloce e preciso della temperatura di saldatura. Grazie ad un elemento termico particolarmente potente di 80 watt è possibile ottenere un comportamento eccezionalmente dinamico. Il tutto, insieme alla forma snella e alla semplice sostituzione della punta, fa sì che questo stilo di saldatura a dolce possa trovare impiego dai più precisi lavori di brasatura sino a simili lavori che richiedono un alto rendimento termico.

Con l'integrato conduttore per la compensazione di potenziale vi è la possibilità di realizzare sulla punta di brasatura la compensazione di potenziale desiderata. Grazie all'esecuzione antistatica dell'impugnatura e del cavo lo stilo per brasatura soddisfa tutti i requisiti della sicurezza EGB.

Dati tecnici

Tensione di collegamento:	24 V
Potenza:	80 W
Tempo di riscaldamento:	ca. 10 sec. (50°C-350°C)
Temperatura massima:	450°C
Collegabile alle:	tutti gli stazioni 80 W

2. Messa in funzione

Appoggiare lo stilo brasatore nel supporto di sicurezza. Tenere lontano dal brasatore tutti gli oggetti infiammabili. Inserire la spina di collegamento (7) nell'unità di alimentazione e arrestare. Impostare sull'unità di alimentazione la temperatura desiderata. Allo scadere del necessario tempo di riscaldamento coprire con dello stagno la punta.

3. Compensazione di potenziale

Attraverso l'apparecchio di alimentazione utilizzato è possibile realizzare una compensazione di potenziale sulla punta di brasatura. Le possibilità di collegamento di un cavo per la compensazione di potenziale sono descritte nel manuale d'uso dell'unità di alimentazione.

I

4. Indicazione di lavoro

Sostituzione della punta

- Tenere in posizione orizzontale lo stilo brasatore.
- Allentare il dado zigrinato della bussola della punta (2).
- Estrarre in avanti la bussola della punta (2).
- Ora la punta di brasatura si trova allentata nella bussola della punta.

Attenzione: la punta di dosatura scotta!

Non appoggiare né lasciar raffreddare la punta del saldatore a stilo / la punta di misurazione sulla spugnetta pulisci-punte o su una superficie di plastica.

Nel caso vengano utilizzati numerosi tipi di punte si raccomanda di utilizzare la punta di saldatura (1) e la bussola per la punta (2) insieme a mo' di sistema di cambio rapido.

Tenere sempre pulite resistenza e punta dello stilo.

Le sostanze sintetiche antistatiche sono provviste di imbottiture conduttrici per evitare il formarsi di cariche statiche. In tale maniera vengono ad essere diminuite anche le caratteristiche di isolamento della sostanza sintetica. Ciò significa che non è permesso eseguire lavori su elementi sotto tensione.

Oltre alle presenti istruzioni d'uso sono da rispettare anche le istruzioni d'uso dell'unità di alimentazione utilizzata.

5. Accessori

Per l'immagine punte LT vedere a pagina 7 - 9.

Con riserva di modifiche tecniche!



1. Description

The Weller micro-solderer WSP 80 features precise and quick heating to the required solder temperature. An excellent dynamic behaviour is achieved using an especially powerful 80W heater element. Together with the slimline form and the simple change of soldering bits, this soldering iron can be universally used in all situations from extremely delicate soldering to those where there is a greater temperature requirement.

With an integrated grounding connector, there is the possibility for a grounding of the solder bit if required. The anti-static handle and cables mean that the soldering iron satisfies all requirements of the EGB safety.

Specifications

Connecting voltage:	24V
Power:	80 W
Warm up time:	approx. 10 sec. (50°C - 350 °C)
Max. temperature:	450 °C
Connectable to:	all 80 W power units

2. Installation

Place the soldering iron in the safety holder. Remove all flammable articles from around the soldering iron. Plug and lock the connector (7) into the supply unit. Set the required temperature on the supply unit. Wet the soldering bit with solder once it has heated up.

3. Grounding

If required, an grounding of the soldering bit can be created via the supply unit. The connection possibilities for grounding are described in the instructions for the supply unit.

4. Information for Operation

Changing soldering bits

- hold soldering iron horizontal.
- loosen the knurled nut around the bit-sleeve (2).
- pull the bit-sleeve (2) towards the front.
- the soldering bit now sits loosely in the sleeve.

Warning: Soldering bit is HOT!

Do not place or leave the hot soldering tip / calibration tip on the cleaning sponge or on plastic surfaces.

When using a number of different solder bits, it is recommended that the soldering bit and sleeve are used together as a quick change system.

Keep the heating element and soldering tip heat transfer surfaces clean.

Anti-static plastics containing conducting fillers are used to prevent static charge build-up. This also means that the insulating properties of the plastic are reduced. No work should be undertaken on articles which are live, or at high voltage.

The instructions for the use of the supply unit are valid in addition to these here.

5. Accessories

Soldering bits figure LT-Tips see pages 7 - 9.

Subject to technical change without notice!

1. Tasvir

Weller Micro Lehim kalemi WSP 80 çalışma ısısına çabuk ulaşan, ısı hassasiyeti ince bir lehim kalemidir. 80 W yüksek performansıyla mükemmel ve dinamik çalışma imkanı sağlamaktadır. Zarif, ince konstrüksiyonlu ve ucu kolayca değiştirilebilen bu lehim kalemi çok ince lehim işlerinden, aşırı ısı gerektiren çalışma şekillerine kadar her türlü işte kullanılabilir.

Entegre edilmiş bir potansiyel denkleme hattı vasıtasıyla lehim kalemi ucuna istediğiniz potansiyel denklemesini yapabilirsiniz. Antistatik model kulp ve hatlarıyla lehim kalemi bütün ATB güvenlik gereksinimlerine uymaktadır.

Teknik veriler

Elektrik voltajı:	24 V
Güçü:	80 W
Isıtma süresi:	takr. 10 san. (50°C-350°C)
Azami sıcaklık:	450°C
Bağlanabileceği birimler:	bütün 80 W beslenim birimleri

2. Kullanıma alış

Lehim aletini yatağına bırakınız. Yakın çevreden bütün yanıcı cisimleri uzaklaştırınız. Elektrik fişini (7) beslenim birimine takınız ve kilitleyiniz. Beslenim biriminde istenilen ısıyı ayarlayınız. Gerekli ısıya ulaşıldıktan sonra lehim kalemi ucuna ince bir lehim tabakası sürünüz.

3. Potansiyel denkleme

Kullanılan beslenim birimi üzerinden lehim kalemi ucuna istenilen potansiyel denkleme yapılabilir. Potansiyel denkleme hattının bağlantı şekilleri için, sözkonusu beslenim biriminin kullanım kitabına bakınız.

TR

4. Kullanımla ilgili notlar

Uç değiştirilmesi

- Lehim kalemini yere yatay tutunuz.
- Uç yuvasının tırtıllı somununu (2) çözünüz.
- Tırtıllı somunu (2) öne doğru çekip çıkarınız.
- Lehim kalemi ucunu şimdi uç yuvasından çekip alabilirsiniz.

Dikkat: Lehim kalemi ucu sıcak!!

Sıcak lehim kalem ucunu / ölçme kalemi ucunu temizlik süngerine veya plastik yüzeylere koymayınız, böyle yerlerde soğumaya bırakmayınız.

Birden fazla tip lehim kalemi ucu kullanıldığında lehim kalemi ucu (1) ve uç yuvalarını (2) birlikte, çabuk değiştirilebilir takımlar halinde kullanmanız tavsiye olunur.

Isıtıcı ve lehim kalemi uçlarının ısı ileten yüzeylerini temiz tutunuz.

Aletin antistatik plastik kısımlarına statik yükleri önlemek için iletken dolgu maddeleri ilave edilmiştir. Bu nedenle plastik kısımların izolasyon özelliği tam değildir. Elektrik gerilimi altında bulunan parçalarla çalışmamaya dikkat ediniz.





Bu kullanım açıklamaları yanında, elektrik beslenim ünitenizin kullanım kitabındaki açıklamaları da dikkate alınız.

5. Aksam



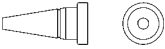

Lehim kalemi uçları Resimler LT uçları bkz. Sayfa 7 - 9.

Teknik değişiklikler yapma hakkı saklıdır!



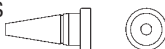



LT-Spitzen für WSP 80 Pannes LT pour WSP 80

Modell Modèle Modello Model Model	Beschreibung Description Descrizione Description Tasvir	Bestell-Nr. N° de commande N° di ord. Order-No. Sipariş No.:
LT 1 	Rundform 0,25 mm Forme ronde 0,25 mm Taglio sbieco 0,25 mm Round tip 0,25 mm Yuvarlak cins 0,25 mm	5 44 401 99
LT 1S 	Rundform 0,2 mm Forme ronde 0,2 mm Taglio sbieco 0,2 mm Round tip 0,2 mm Yuvarlak cins 0,2 mm	5 44 402 99
LT A 	Meißelform 1,6 mm Tournevis 1,6 mm Cacciavite 1,6 mm Chisel tip 1,6 mm Keski cinsi 1,6 mm	5 44 403 99
LT AS 	Rundform 1,6 mm Forme ronde 1,6 mm Taglio sbieco 1,6 mm Round tip 1,6 mm Yuvarlak cins 1,6 mm	5 44 404 99
LT B 	Meißelform 2,4 mm Tournevis 2,4 mm Cacciavite 2,4 mm Chisel tip 2,4 mm Keski cinsi 1,6 mm	5 44 405 99

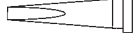

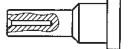





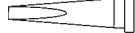

Punte LT per WSP 80 LT-Tips for WSP 80 LT-lehim kalemi uçları, WSP 80 için

Modell Modèle Modello Model Model	Beschreibung Description Descrizione Description Tasvir	Bestell-Nr. N° de commande N° di ord. Order-No. Sipariş No.:
LT C 	Meißelform 3,2 mm Tournevis 3,2 mm Cacciavite 3,2 mm Chisel tip 3,2 mm Keski cinsi 3,2 mm	5 44 407 99
LT CS 	Rundform 3,2 mm Forme ronde 3,2 mm Taglio sbieco 3,2 mm Round tip 3,2 mm Yuvarlak cins 3,2 mm	5 44 411 99
LT D 	Meißelform 4,6 mm Tournevis 4,6 mm Cacciavite 4,6 mm Chisel tip 4,6 mm Keski cinsi 4,6 mm	5 44 409 99
LT H 	Meißelform 0,8 mm Tournevis 0,8 mm Cacciavite 0,8 mm Chisel tip 0,8 mm Keski cinsi 0,8 mm	5 44 412 99
LT HX 	Meißelform gebogen 0,8 mm Tournevis coudée 0,8 mm Cacciavite curva 0,8 mm Chisel tip, bent 0,8 mm Keski cinsi, kıvrık 0,8 mm	5 44 420 99

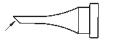



LT-Spitzen für WSP 80 Pannes LT pour WSP 80

Modell Modèle Modello Model Model	Beschreibung Description Descrizione Description Tasvir	Bestell-Nr. N° de commande N° di ord. Order-No. Sipariş No.:
LT K  	Meißelform 1,2 mm Tournevis 1,2 mm Cacciavite 1,2 mm Chisel tip 1,2 mm Keski cinsi 1,2 mm	5 44 413 99
LT GW 	Lötspitze für Gull wings 3,2 mm Pannes pour Gull wings 3,2 mm Punte per Gull wings 3,2 mm Tips for Gull wings 3,2 mm Gull wings için lehim kalemi uçları 3,2 mm	5 44 410 99
	Meßspitze Panne de mesure Punta di misurazione Calibration tip Ölçme ucu	5 44 416 99
LT S  	Langform konisch 0,4 mm Longue conique 0,4 mm Concia lunga 0,4 mm Long tip, conical 0,4 mm Uzun cins, konik 0,4 mm	5 44 406 99
LT F  	Rundform abgeschrägt 1,2 mm Ronde tronquée 1,2 mm Conica taglio sbieco 1,2 mm Round tip, spade 1,2 mm Yuvarlak cins, eğik 1,2 mm	5 44 408 99

Punte LT per WSP 80 LT-Tips for WSP 80 LT-lehim kalemi uçları, WSP 80 için

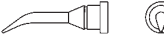
Modell Modèle Modello Model Model	Beschreibung Description Descrizione Description Tasvir	Bestell-Nr. N° de commande N° di ord. Order-No. Sipariş No.:
LT L  	Langform Meißel 2,0 mm Longue Tournevis 2,0 mm Cacciavite lungo 2,0 mm Long chisel tip 2,0 mm Uzun cins keski 2,0 mm	5 44 414 99
LT M  	Langform Meißel 3,2 mm Longue Tournevis 3,2 mm Cacciavite lungo 3,2 mm Long chisel tip 3,2 mm Uzun cins keski 3,2 mm	5 44 415 99
LT 4  	Rundform abgeschrägt 1,6 mm Ronde tronquée 1,6 mm Conica taglio sbieco 1,6 mm Round tip, spade 1,6 mm Yuvarlak cins, eğik 1,6 mm	5 44 421 99
LT 1L  	Langform konisch 0,25 mm Longue conique 0,25 mm Concia lungo 0,25 mm Long tip, conical 0,25 mm Uzun cins, konik 0,25 mm	5 44 423 99
LT 1LX  	Langform gebogen 0,25 mm Longue Tournevis courbée 0,25 mm Cacciavite lungo curva 0,25 mm Long tip, bent 0,25 mm Uzun cins, kıvrık 0,25 mm	5 44 424 99

LT-Spitzen für WSP 80 Pannes LT pour WSP 80

Modell Modèle Modello Model Model	Beschreibung Description Descrizione Description Tasvir	Bestell-Nr. N° de commande N° di ord. Order-No. Sipariş No.:
LT 1X 	Rundform gebogen 0,4 mm Ronde courbée 0,4 mm Cono tronco curva 0,4 mm Round tip, bent 0,4 mm Yuvarlak cins, kıvrık 0,4 mm	5 44 425 99
LT 1SLX 	Rundform gebogen 0,4 mm Ronde courbée 0,4 mm Cono tronco curva 0,4 mm Round tip, bent 0,4 mm Yuvarlak cins, kıvrık 0,4 mm	5 44 426 99
LT AX 	Rundform gebogen 1,6 mm Ronde courbée 1,6 mm Cono tronco curva 1,6 mm Round tip, bent 1,6 mm Yuvarlak cins, kıvrık 1,6 mm	5 44 427 99
LT 4X 	Meißelform gebogen 1,2 mm Tournevis courbée 1,2 mm Cacciavite curva 1,2 mm Chisel tip, bent 1,2 mm Keski cinsi, kıvrık 1,2 mm	5 44 428 99
LT Entlötpitze 	Entlötpitze 10,5 mm Pannes à dessouder 10,5 mm Punte dissaldanti 10,5 mm Desoldering tip 10,5 mm Lehim silme kalemi ucu 10,5 mm	5 44 429 99

Punte LT per WSP 80 LT-Tips for WSP 80 LT-lehim kalemi uçları, WSP 80 için

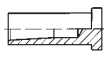
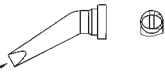
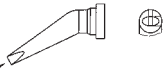
Modell Modèle Modello Model Model	Beschreibung Description Descrizione Description Tasvir	Bestell-Nr. N° de commande N° di ord. Order-No. Sipariş No.:
LT Adapter für SMD-Spitzen 	Adapter Adaptateur Adattatore Adaptor Adaptör	5 44 417 99
LT BX 	Meißelform gebogen 2,4 mm Tournevis courbée 2,4 mm Cacciavite curva 2,4 mm Chisel tip, bent 2,4 mm Keski cinsi, kıvrık 2,4 mm	5 44 442 99
LT ALX 	Meißelform gebogen 1,6 mm Tournevis courbée 1,6 mm Cacciavite curva 1,6 mm Chisel tip, bent 1,6 mm Keski cinsi, kıvrık 1,6 mm	5 44 443 99



COOPER Hand Tools

Cooper Tools GmbH

Carl-Benz-Straße 2, 74354 Besigheim,
Postfach 1351, 74351 Besigheim,
Germany
Tel.: (07143) 580-0
Fax:(07143) 580-108

CooperTools S.A.

76 Rue François de Tesson, B.P. 46,
77831 Ozoir la Ferriere,
France
Tél: (1) 60.18.55.40
Fax: (1) 64.40.33.05

Cooper Italia S.p.A.

Viale Europa 80,
20090 Cusago (MI)
Italy
Tel.: (02) 9033101
Fax: (02) 90394231

Cooper Tools

Suite 15, Coniston House
Town Centre, Washington
Tyne and Wear NE38 7RN,
Great Britain
Phone: (0191) 4197700
Fax: (0191) 4174721

Erem S.A.

8, Rue de la Roselière
1400 Yverdon les Bains
Switzerland
Tél: (024) 4 26 12 06
Fax: (024)4 25 09 77